



SERVICE BULLETIN

No. 565

Piper Aircraft Corporation

Lock Haven, Pennsylvania, U.S.A.

"DOA SO-1 Approved"

June 2, 1977

M

Subject:

Edo Aire Mitchell Service Bulletin No. MB-13, dated May 3, 1977; Modification to Edo Aire Mitchell NSD-360 Horizontal Situation Indicator.

*Models Affected:

*Serial Numbers Affected:

PA-28R-200 Arrow II	28R-7635001 to 7635529 inclusive;
PA-28R-201 Arrow III	28R-7737001 to 7737068 inclusive;
PA-28R-201T Turbo Arrow III	28R-7703001 to 7703138 inclusive;
PA-32-260 Cherokee Six 260	32-7600001 to 7700017 inclusive;
PA-32-300 Cherokee Six 300	32-7640001 to 7740075 inclusive;
PA-32R-300 Cherokee Lance	32R-7680001 to 7780350 inclusive;
PA-34-200T Seneca II	34-7670001 to 7770261 inclusive.

* With Edo-Aire Mitchell NSD-360 compass system installation only.

Compliance Time: Refer to Page two (2) of Edo-Aire Mitchell Service Bulletin, paragraph entitled, "Effective Within the Next Fifty Flight Hours".

Purpose: To disseminate the information contained in the attached copy of Edo-Aire Mitchell Service Bulletin MB-13, dated May 3, 1977, and to furnish specific modification/installation instructions for the aircraft referenced above.

Instructions:

NOTE

Use the following instructions in lieu of those contained on pages two and three of MB-13.

1. Remove the pilot and copilot seats from the aircraft.
2. Refer to Sketch "A" of this Service Bulletin for detailed installation instruction of the Nav Flag Adapter (Mitchell Part Number 1C775).
3. Refer to Sketch "B" of this Service Bulletin for all references to "View A-A" and general location information.

Instructions: (Continued)

4. Wiring Instructions: (Refer to Drawing 63D337-2, on Page eight (8) of MB-13 for a pictorial representation of the following instructions).
 - a. Disconnect plug CD-106 from rear of the NSD-360 unit and remove all necessary cable restraints for approximately eight (8) inches to obtain sufficient cable freedom.
 - b. Locate the wire routed from pin seven (7) of CD-106, (refer to View A-A) and cut this wire approximately six (6) inches from the plug. Locate the WHT/VIOLET wire in the 30C550 cable harness and attach it to the six (6) inch wire leading from pin seven (7) of CD-106. Use the 29559 butt splice to make all connections.
 - c. Locate the WHT/BLK/VIOLET wire in the 30C550 cable and attach it to the other half of the wire that was attached to pin seven (7) in "b", above.
 - d. Locate the wire routed from pin eight (8) at CD-106, and cut this wire approximately six (6) inches from the plug. Locate the WHT/GRY wire in the 30C550 cable and attach it to the six (6) inch wire leading from pin eight (8).
 - e. Locate the WHT/BLK/GRY wire in the 30C550 cable and connect it to the other half of the wire that was attached to pin eight (8) in "d", above.
 - f. Locate the wire routed from pin 33 of CD-106, and cut this wire approximately six (6) inches from plug CD-106. Locate the WHT/ORG wire in the 30C550 cable and attach it to the six (6) inch wire leading from pin 33.
 - g. Locate the WHT/BLK/ORG wire in the 30C550 cable and connect it to the other half of the wire that was attached to pin 33 in "f", above.
 - h. Locate the wire routed from pin 34 of CD-106, and cut this wire approximately six (6) inches from the plug. Locate the WHT/YEL wire coming from the 30C550 cable and attach it to the six (6) inch wire leading from pin 34.
 - i. Locate the WHT/BLK/YEL wire in the 30C550 cable and attach it to the other half of the wire that was attached to pin 34 in "h", above.
 - j. Connect the WHT/RED wire to the appropriate Nav Receiver circuit breaker. DO NOT connect it to the NSD-360 circuit breaker.
 - k. Route the WHT/BLK wire to any convenient place and attach it to the airframe, making sure all paint has been removed so there is a good ground.

Instructions: (Continued)

5. Re-tie all wire bundles in an airworthy manner. Ref. Instructions: No. five (5) on Page three of MB-13 (attached).
6. Replace the pilot and copilot seats.
7. Make appropriate log book entry that Service Bulletin MB-13 and this Service Release have been complied with.

Material Required: Placard, Edo-Aire Mitchell Part Number 13A895 and Nav Flag Adapter Edo Aire Mitchell Part Number 1C775. (Refer to Page two (2) of MB-13).

Availability of Parts: Your Piper Field Service Facility.

Effectivity Date: This Service Bulletin is effective upon receipt.

Summary: Please contact your Piper Field Service Facility to make arrangements for compliance with this Service Bulletin. Material for compliance with this Service Bulletin must be ordered through your Piper Field Service Facility but it will be shipped from Edo-Aire Mitchell direct to the ordering agency. Material will be furnished on a no cost basis provided the directions one (1) through four (4) on Page three in Service Bulletin MB-13 are complied with at the time the order is placed. Four (4) hours labor allowance credit will be provided for installation of the kit required by MB-13.

.221 DIA. THRU (2 REQ'D)
RIVNUT, B.F. GOODRICH # AK8-75 (2 REQ'D)
SCREW, AN525-832-R8 (2 REQ'D)
WASHER, AN960-8 (2 REQ'D)

CD-151

CABLE ASSY
(MITCHELL P/N 30C550)

NAV FLAG ADAPTER
(MITCHELL P/N 1C775)

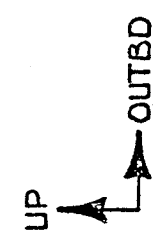

FIREWALL
F.S. 44.80 (PA28)
F.S. 49.50 (PA32 + PA34)

VIEW LOOKING FWD ON
CO-PILOT'S SIDE OF AIRCRAFT

AIRCRAFT

SKETCH A

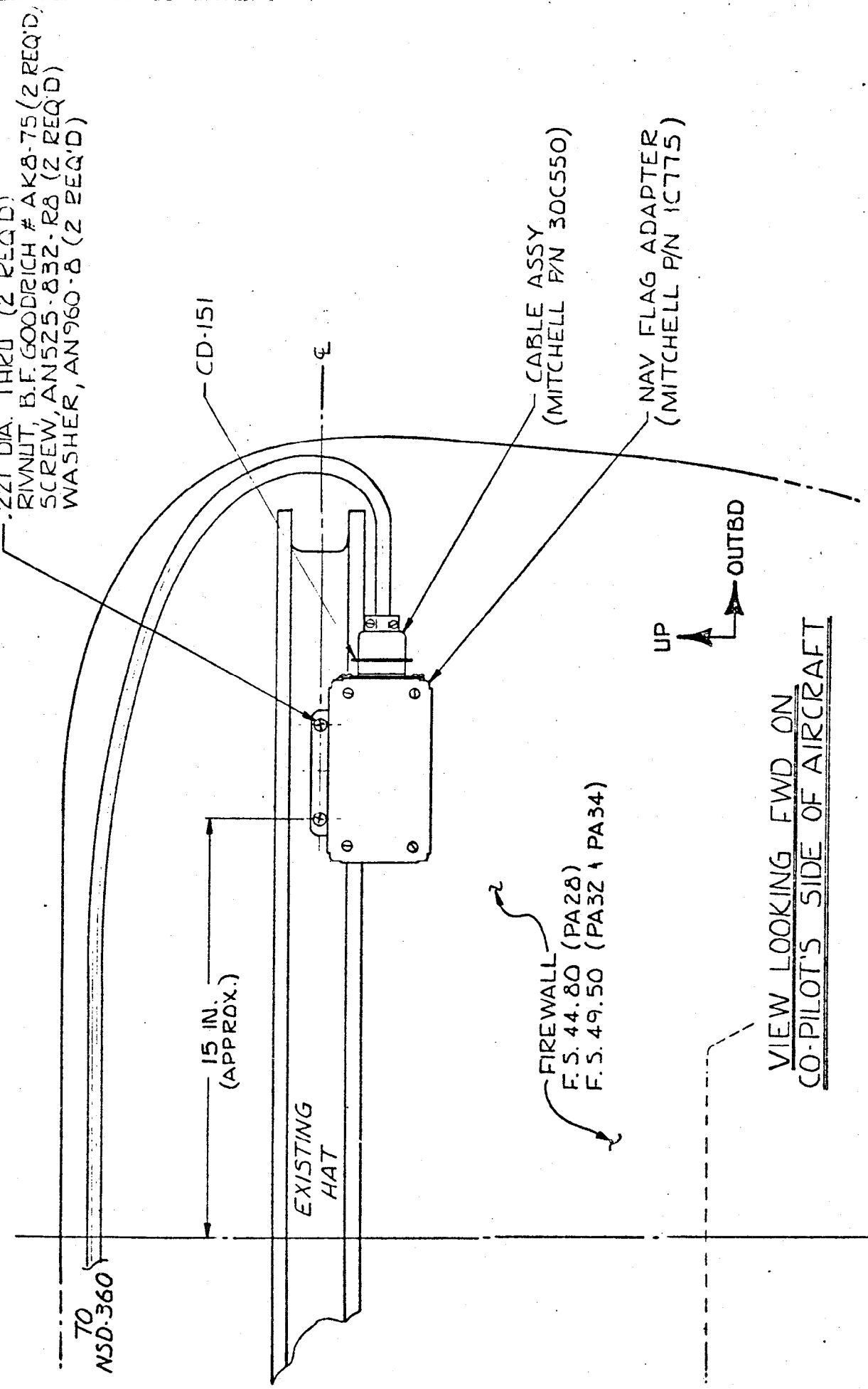

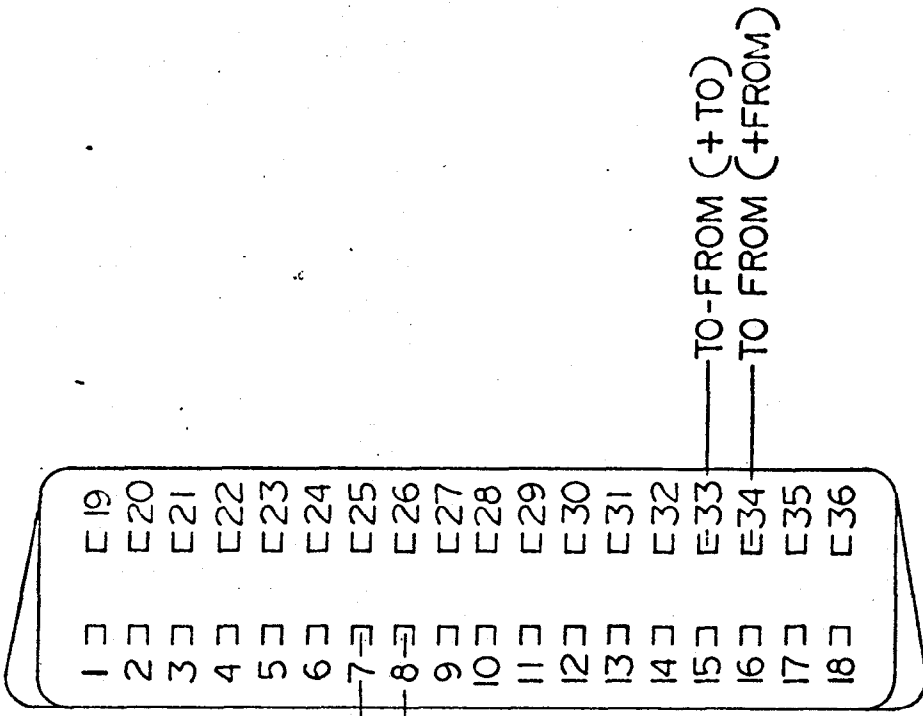

NAV FLAG -
NAV FLAG +

TO-FROM (+ TO)
TO FROM (+FROM)

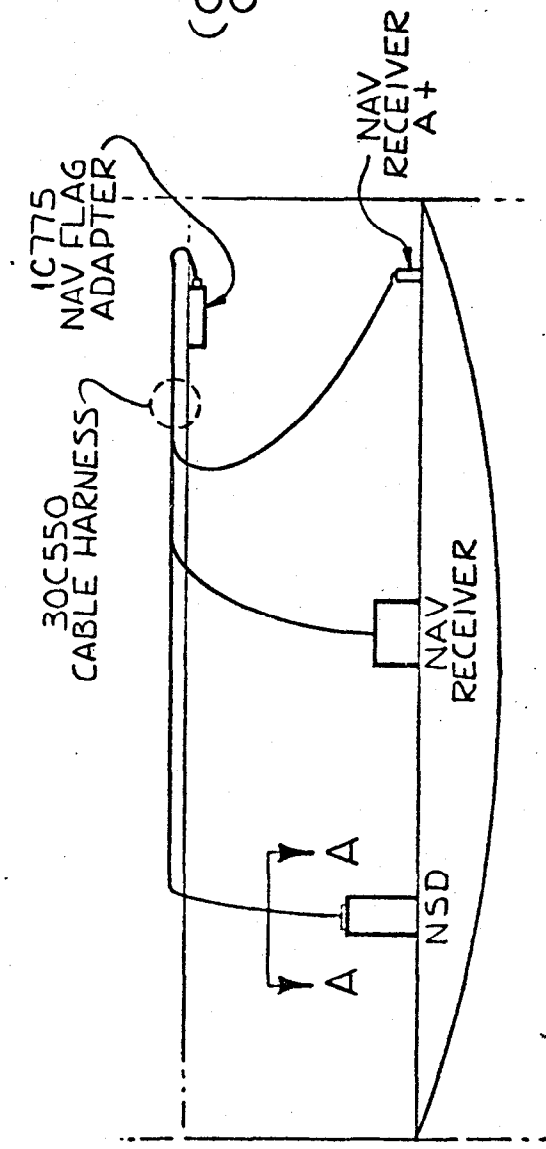

VIEW A-A
(CD-106 WITH PLUG COVER REMOVED)

SKETCH B



SERVICE BULLETIN

NO MB-13

FAA-DER APPROVED

DATE 4-18-77
5-03-77 Revised

EDO-AIRE MITCHELL

TO Owners of Edo-Aire Mitchell
NSD-360 Compass Systems and
Edo-Aire Mitchell Distributors

SUBJECT Interface Incompatibility
with Certain Navigation
Receivers/ Converters

It has been determined that an interface incompatibility may exist in certain NSD-360 Compass System installations that do not use the Edo-Aire Mitchell AK423, 1C707, or 1C707-1 VOR/Localizer Converters.

The affected NSD-360 Compass Systems contain one of the following navigation instruments:

P/N 52D136-0020	52D136-1020	52D137-1020
52D136-0120	52D136-1120	52D137-1120
52D136-0220	52D136-1220	52D137-1220

The interface incompatibility does not exist with systems using navigation instruments other than those listed above, nor with the NSD-360A Compass Systems. The NSD-360A systems do not use any of the navigation instruments listed above.

The interface incompatibility also does not exist with the ARC IG832-() or IG895-().

In those installations where the incompatibility does exist, it is possible for a defective VOR Navigation Signal that is not suitable for navigation to be displayed with the navigation (NAV) flag hidden from view thus indicating to the pilot that the signal is reliable when in fact it is not reliable.

The incompatibility is caused by the NSD-360 being designed to be used with VOR/LOC Converters having a "gated" To-From function. A gated To-From output is one that is blocked during NAV flag visible conditions thus preventing display of the "TO" arrow or "FROM" arrow. A gated To-From is required so that the combined To-NAV-From meter in the NSD-360 will give correct information when unsatisfactory navigation signals are present.

EFFECTIVE WITHIN THE NEXT FIFTY FLIGHT HOURS:

The NSD-360 is not to be used as a primary IFR VOR/Localizer Navigation Instrument, unless it is used with an Edo-Aire Mitchell AK423, Omni Converter, P/N 1C707, or P/N 1C707-1. The VOR/Localizer Left-Right data may continue to be used but displayed Flag information must be cross checked with the #2 system to assure validity of the presentation. The Compass Data, and Glide Slope Data displayed on the NSD-360 are not affected and may continue to be used as primary IFR instrumentation. This restriction may be removed by installing a NAV Flag Adapter, P/N 1C775, furnished with Parts Kit PKMB-13. Parts Kit PKMB-13 will be furnished at no charge.

For the affected aircraft, Placard, P/N 13A895, must be installed on the instrument panel, as close as practical to the NSD-360 Navigation Instrument, prior to any further I.F.R. flight, or until the restriction is removed by installation of the NAV Flag Adapter, P/N 1C775.

INSTALLATION OF NAV FLAG ADAPTER, P/N 1C775:

1. The 1C775 NAV Flag Adapter is a small light weight unit (0.3 lb.). It is to be mounted on existing structure between the instrument panel and forward cabin bulkhead or firewall, near the rear of the NSD-360 Navigation Instrument.
2. Using Drawing No. 1C775 as a guide, locate an area with sufficient space and structure to support the NAV Flag Adapter, and mark and drill two .173 dia. (No. 17 drill) holes.
3. Secure the unit to the aircraft structure, using two each of the 8-32 screws, washers, and nuts supplied with PKMB-13.
4. Drawing No. 63D337-2 shows the interconnect wiring between the NSD-360 navigation instrument and the 1C775 NAV Flag Adapter. The four wires indicated, which are a part of the cable bundle to CD-106 of the NSD-360, are to be intercepted as close as feasible to CD-106, and the leads of Adapter Cable, P/N 30C550, are to be connected as shown on Drawing No. 63D337-2. Plug the CD-151 Plug of the 30C550 Cable into the CD-151 Receptacle of the 1C775 NAV Flag Adapter. Route the cable to CD-106 of the NSD-360, leaving sufficient service loop to adequately secure the cable. Cut the wire leads to the proper length and connect to the NSD-360 cable leads as shown using eight 29S59 butt splices. The ground lead of the 30C550 Cable should be routed to a convenient airframe ground. The A+ lead should be connected to the circuit breaker of the navigation receiver that is associated with the NSD-360. Do not connect the A+ to the NSD-360 circuit breaker!

5. All cables should be routed clear of flammable fluid and oxygen lines. Secure cables to airframe with AN742 cushion clamps within a maximum spacing of 18 inches to prevent damage and allow full freedom of controls. All open cable connections and interconnections, shall be protected with a suitable insulating sleeve which shall be secured in accordance with good aviation wiring practices. Polyvinyl chloride sleeving material is an acceptable insulator. Ref. AC 43.13-1A, Chapter 11.

Approved Edo-Aire Mitchell Distributors may apply for labor reimbursement for the installation of PKMB-13. This labor reimbursement is for a maximum of two hours at approved labor rates per aircraft installation, and is available only through approved Edo-Aire Mitchell Distributors. Flight Adjustment should not be required as a result of this modification.

When ordering the Parts Kit and/or submitting claims for labor reimbursement under this Service Bulletin, MB-13, the following information must be included:

1. Aircraft Owners Name.
2. Aircraft Model, Serial Number, and Registration Number.
3. NSD-360 Navigation Instrument Part Number.
4. NSD-360 Navigation Instrument Serial Number.

If the above data is not available at the time of order, the PKMB-13 will be shipped at \$75.00 net, to be credited to customer's account when the data is received by Edo-Aire Mitchell.

Where Placard, P/N 13A895, is installed in lieu of NAV Flag Adapter, P/N 1C775, this service bulletin shall be placed with the aircraft service records, and a log book entry made to reflect compliance with Edo-Aire Mitchell Service Bulletin, MB-13. The placard is attached to this service bulletin, however, an additional placard may be obtained from Edo-Aire Mitchell at no charge if it is lost or destroyed.

Where the NAV Flag Adapter, P/N 1C775 is installed, this service bulletin shall be placed with the aircraft service records and a log book entry made to reflect compliance with Edo-Aire Mitchell Service Bulletin, MB-13.

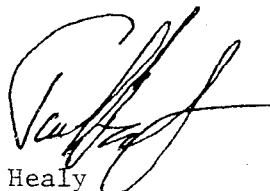

Tom Healy
Director, Products and Service
EDO-AIRE MITCHELL

PK MB-13

PARTS LIST FOR EDO-AIRE MITCHELL SERVICE BULLETIN MB-13

Item No.	Part Number	Description	Quantity
1.	1C775	NAV Flag Adapter	1 _____
2.	30C550	Cable Assembly	1 _____
3.	3S464	Screw, AN525-832-R8	2 _____
4.	4S205	Washer, AN960-8	2 _____
5.	2S34	Nut, #8-32 ESNA, AN365-832	2 _____
6.	29S59	Butt Splice	8 _____
7.	MB-13	Service Bulletin	1 _____

EDO-AIRE MITCHELL MINERAL WELLS, TEXAS		TITLE PLACARD		DWG. NO. 13A895	
DRAWN C. KITCHENS	DATE 12-22-76	USED WITH SERVICE BULLETIN, MB-13, IC 775, NAV FLAG ADAPTER (NSD-360 COMPASS SYSTEMS)		REV.	DESCRIPTION
CHECKED E. Cameron	DATE 12-23-76	FINISH	SCALE	-	RELEASED PER E.O. 9276
ENGINEER <i>Alvin</i>	DATE 12-23-76	MATERIAL	N/A	BY	DATE
APPROVAL <i>J. Alvin</i>	DATE 12-23-76			HWH	1-20-77

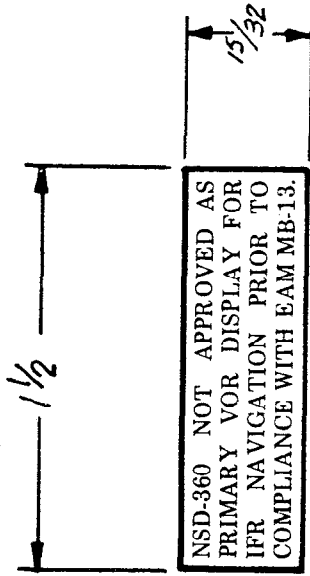

NOTES:

- MATERIAL:
AVERY SELF-ADHESIVE DIE CUT LABEL FOR PRINTING,
1" x 2 3/4" RETANGULAR P/N 5562. GOTHIC LETTERS. TRIM TO 1 1/2" x 1 5/32"
- VENDOR:
AVERY LABEL COMPANY, A DIVISION OF AVERY PRODUCTS CO.
MONROVIA, CALIF. 91016
OR: ELMHURST, ILL.
NEW BRUNSWICK, N.J.
- REFERENCE: SERVICE BULLETIN #MB-13, DATED

THIS DRAWING IS THE PROPERTY OF EDO-AIRE MITCHELL AND ITS POSSESSION BY UNAUTHORIZED PERSONS SHALL NOT BE CONSTRUED AS PERMISSION TO REPRODUCE FOR SALE, IN WHOLE OR IN PART, ANY DEVICES SHOWN THEREON.

TOLERANCES UNLESS OTHERWISE SPECIFIED:
 DECIMALS: ± .003
 DECIMALS: XX: ± .010
 FRACTIONS: ± 1/64
 ANGLES: ± 0°30'
 REMOVE BURRS AND BREAK SHARP EDGES .010
 DO NOT SCALE DRAWING

REV	DESCRIPTION	DATE	APPROVED
1	RELEASED PER E.O. 7178	1-19-77	J. L. L. D. W.

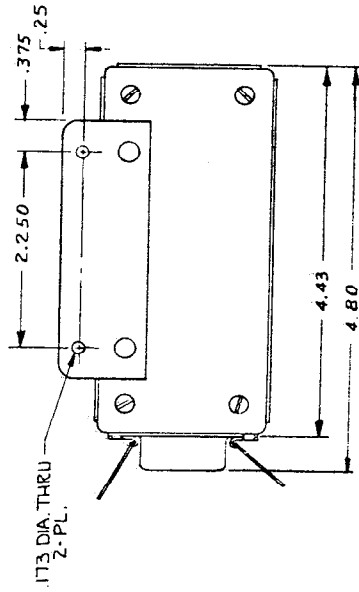
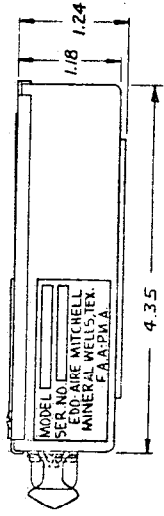
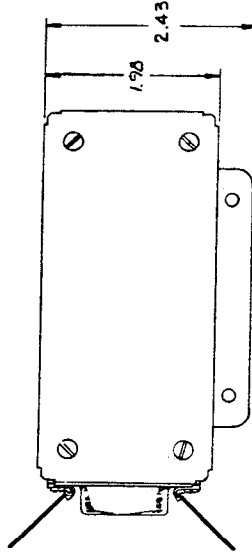

CD-151

1	8	TO/FROM (+TO) OUTPUT TO PIN 33 OF NSD-340
2	9	TO/FROM (+TO) INPUT FROM CONV.
3	10	N/C
4	11	N/C
5	12	A+ (A/2BY)
6	13	N/C
7	14	TO/FROM (+FROM) INPUT FROM CONV.

RECEPTACLE 14-PIN
 AMPHENOL # 57-40140
 MATE'S WITH AMPHENDL
 # 57-30140

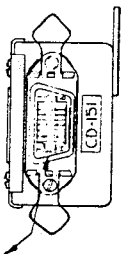

- NOTES:
1. WT:
 2. REFER TO 12AX5 FOR ENGINEERING SPECIFICATIONS.
 3. REFER TO 91A307 FOR DATA SHEET.
 4. REFER TO 63C504 FOR SCHEMATIC.
 5. WEIGHT: 0.3 LBS.

REFER TO 79C269 FOR FINAL ASSEMBLY DRAWING	
CITY ITEM PART NUMBER	DESCRIPTION
LIST OF MATERIALS	
DRAWN	J. PATTERSON 11-3-76
CHECKED	C. WILSON 11-13-76
ENGINEER	11-29-76
APPROVED	1-19-77
TITLE	
EDO-AIRE MITCHELL MINERAL WELLS, TEXAS	
NAV FLAG ADAPTER OUTLINE DRAWING	
SHEET	DWG NO.
C	IC775
SCALE FULL	SHEET 1 OF 1

THE RIGHTS IN THE PROPERTY OF MITCHELL	
DO NOT BE REPRODUCED OR TRANSMITTED IN ANY FORM OR BY ANY MEANS, ELECTRONIC OR MECHANICAL, INCLUDING PHOTOCOPYING, RECORDING, OR BY ANY INFORMATION STORAGE AND RETRIEVAL SYSTEM.	
TOLERANCES UNLESS OTHERWISE SPECIFIED	
FRACTIONS 1/16 1/8 3/16 1/4 3/8 1/2	
DECIMALS .001 .002 .005 .010 .015 .030 .045 .060 .075 .090 .125 .150 .1875 .250 .3125 .375 .500 .625 .750 .875 .9375	
ANGLES 15° 30° 45° 60° 75° 90° 105° 120° 135° 150° 165° 180°	
UNLESS OTHERWISE SPECIFIED	
DO NOT SCALE DRAWING	
MATERIAL	N/A
FINISH	N/A
NEXT ASSY	USED ON
APPLICATION	

REVISIONS

NO.	DESCRIPTION	DATE	APPROVED
1	RELEASED PER E.O. 92566	2-277	C.H.L./D.M.

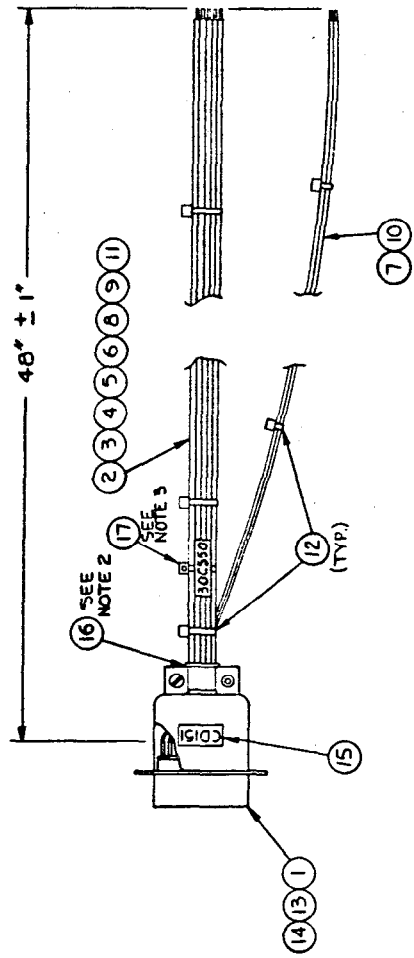

1	* 22 AWG	WHT/BLACK/GRAY
2	* 22 AWG	WHT/BLACK/VIOLET
3	* 22 AWG	WHT/VIOLET
4	* 22 AWG	WHT/YELLOW
5	* 22 AWG	WHT/GRAY
6	* 22 AWG	WHT/BLK
7		
8	* 22 AWG	WHT/ORANGE
9	* 22 AWG	WHT/BLACK/ORANGE
10		
11		
12	* 22 AWG	WHT/RED
13		
14	* 22 AWG	WHT/BLACK/YELLOW

SEE NOTE 2

QTY	ITEM	PART NUMBER	DESCRIPTION
1	17	425254	MARKER TIE, PANDUIT
1	16	11M263	POLYURETHANE TAPE, 1/8 THK. X 1/2 WD. X 1 3/4 LONG
1	15	13AB91	LABEL, CD-151
A/R	14	10M85	SOLDER
A/R	13	11M267	TUBING, HEAT SHRINKABLE, 3/32 DIA.
A/R	12	425253	TIE WRAP, PANDUIT MINIATURE, PNPLT15M
1	11	10M347	WIRE, 22 AWG, WHT/BLK/YELLOW, 48" LONG
1	10	10M339	WHT/RED
1	9	10M346	WHT/BLK/ORANGE
1	8	10M352	WHT/ORANGE
1	7	10M351	WHT/BLK
1	6	10M446	WHT/GRAY
1	5	10M340	WHT/YELLOW
1	4	10M369	WHT/VIOLET
1	3	10M349	WHT/BLK/VIO
1	2	10M380	WIRE, 22 AWG, WHT/BLK/GRY, 45" LONG
1	1	205566	PLUG, 14 PIN, AMPHENOL #57-30140

LIST OF MATERIALS	
DRAWN	B. KEHRER 1-20-77
CHECKED	C. WILTON 1-22-77
ENGINEER	1-22-77
APPROVED	1-22-77
TITLE	EDO-AIRE MITCHELL MINERAL WELLS, TEXAS
ADAPTER CABLE FOR IC775 TO VOR/LOC CONVERTER & NSD360	
REV	30C550
SCALE	NONE
TOT. PAGES	1 OF 1

- NOTES:**
1. STRIP & TIN ALL WIRES 1/8 INCH.
 2. TAPE TO BE WRAPPED AROUND WIRES AND BETWEEN PLUG CLAMP TO INSURE WIRE STABILITY.
 3. P/N 30C550 TO BE IMPRINTED ON MARKER TIE.

PROPERTY	VALUE
STRENGTH	
ELONGATION	
TENSILE	
COMPRESSION	
IMPACT	
TEMPERATURE RANGE	
RESISTANCE	
WEAR	
CORROSION	
FLAMMABILITY	
TOXICITY	
ENVIRONMENTAL	
OTHER	
MATERIAL	N/A
FINISH	N/A
NEST ASSY	USED ON
APPLICATION	

REVISIONS		DATE	APPROVED
1	RELEASED PER E.O. 12812	1-14-77	ACK
2	REVISED PER E.O. 9356		

**IC775
NAV FLAG ADAPTER
CD-151**

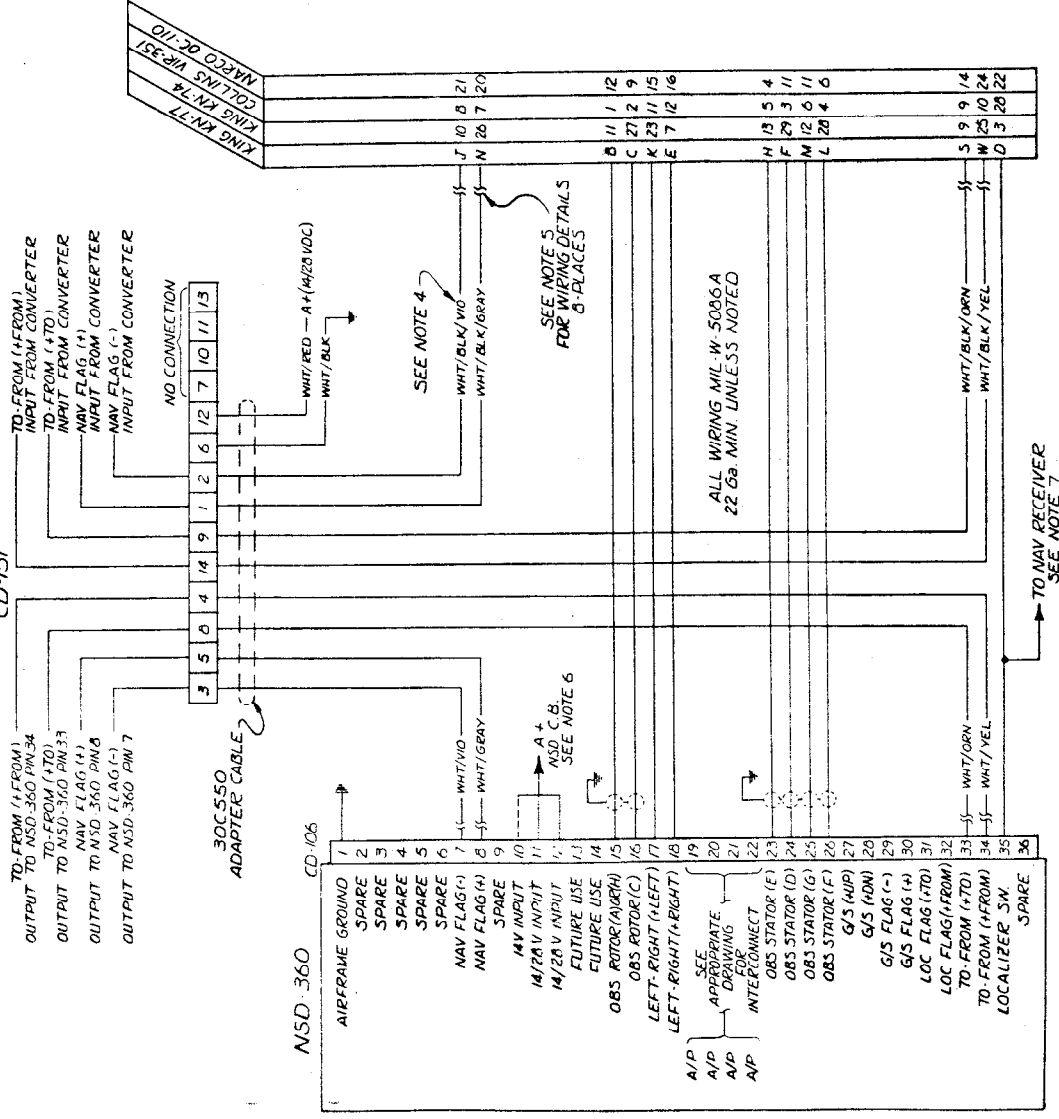

- NOTES FOR INSTALLATION OF VARIOUS NSD-360'S & IC775 NAV FLAG ADAPTER WITH VARIOUS VOR/LOC CONVERTERS:**
- THIS DRAWING IS USED WHEN THE NSD-360 COMPASS SYSTEM IS USED WITH CONVERTERS OTHER THAN THE EDO-AIRE MITCHELL OMNI CONVERTER, PAI/CODT THESE INSTALLATIONS REQUIRE THE IC775 NAV FLAG ADAPTER BETWEEN THE NSD-360 AND CONVERTER AS SHOWN.
 - REFER TO 66399 CENTURY II SERVICE MANUAL OR 66595 OMNI CONVERTER SERVICE MANUAL, PAGE 2-3, FOR WIRING INFORMATION ON NON-SLAVED 52D36'S WITH SERIAL NUMBERS ENDING IN NO LETTER SUFFIX OR SUFFIX 'A'.
 - REFER TO CONVERTER MFGS. INSTRUCTIONS FOR ADDITIONAL WIRING REQUIREMENTS.
 - WIRE COLOR CODES SHOWN REFER TO 30C550 ADAPTER CABLE.
 - REFER TO SERVICE BULLETIN MB-13 OR TO NSD-360 BULLETIN NO'S 479, 600 OR 668 FOR ADDITIONAL WIRING REQUIREMENTS AND INSTALLATION INSTRUCTIONS.
 - FOR 14V INPUT, JUMPER 10 11 AND 12.
 - FOR 14/28V ON CD-106 GROUNDS WHEN LOCALIZER FREQUENCY IS SELECTED. SOME RADIO SUPPLY AT, IN THESE CASES A RELAY WILL BE REQUIRED.

EDO-AIRE MITCHELL MINERAL WELLS, TEXAS		
DATE: 1/15/77	REV: 1	DWG NO: 63D337-2
REVISED PER E.O. 12812	DATE: 1-23-77	REV: D
APPROVED: 1-20-77	DATE: 1-20-77	REV: ~
INTERCONNECT NSD-360 WITH VARIOUS VOR/LOC CONVERTERS & IC775 NAV FLAG ADAPTER		
APPLICATION		
TEST ASSEMBLY	USED ON	UNIT
FINISH	DATE	NO.