

**SERVICE BULLETIN**

Compliance Will Enhance Safety

**SB19-09**TECHNICAL PORTIONS  
FAA APPROVED

**SUBJECT:** Champion Aerospace Slick Service Bulletin SB2-19

**PURPOSE:** Required inspection of impulse coupled Slick by Champion magnetos.

**COMPLIANCE:** Reference detailed compliance requirements as directed by the attached Champion Aerospace Slick Service Bulletin SB2-19.

**MODELS**

**AFFECTED:** New and rebuilt O-200-A, B, D, X; IO-240-A, B; IO-360-ES, KB; LTSIO-360-EB, KB, RB; TSIO-360-CB, EB, FB, GB, KB, LB, MB, RB, SB; O-470-R, S, U; IO-470-C, F, J, K, L, N, S, V, VO; IO-520-A, BA, BB, C, CB, D, F, J, L, M; LTSIO-520-AE; TSIO-520-AE, AF, BE, C, CE, D, DB, G, H, M, P, R, T, UB; IO-550-B, C, D, F, L; and TSIO-550-C, E. Listed engine models may have been equipped with affected Slick by Champion magneto models from the factory. Additional engine models may have affected Slick magneto models installed in accordance with Type Certificate Data Sheet (TCDS).

**I. GENERAL INFORMATION**

Continental Aerospace Technologies™ (Continental®) recommends customer compliance, as specified in Champion Aerospace Slick Service Bulletin SB2-19.

Perform required inspection of any 4200/4300/4700 series or 6200/6300/6700 series impulse coupled magnetos as specified in Champion Aerospace Slick Service Bulletin SB2-19. For your convenience, please use the following cross-reference table to identify affected Continental Part Numbers:

Part Numbers	
SLICK	Continental
4201	642487
4301	653262
6210	642306
6214	642784
6220	646816
6224	643648
6310	653267
6314	653271
6320	653280
6324	653292

**II. WARRANTY**

Direct all questions regarding the actions required by the attached Service Bulletin to:

Champion Aerospace LLC  
1230 Old Norris Road  
Liberty, SC 29657 USA  
Champion Slick Piston Helpline: 904-772-1909

*Intentionally Left Blank*

# Service Bulletin

**TO:** Aircraft Manufacturers, Aircraft Engine Manufacturers, Distributors, Dealers, Engine Maintainers, Engine Overhaul Facilities, Owners and Operators of Slick Aircraft Magnetos.

**SUBJECT:** Mandatory inspection of impulse coupled Slick by Champion magnetos.

**MAGNETO MODELS**

**AFFECTED:** The following magneto models with serial numbers between 15021147 and 19020180: 4301, 4303, 4316, 4330, 4333, 4354, 4371, 4372, 4373, 4374, 4381, 4392, 4755, 6310, 6314, 6320, 6324, 6331, 6351, 6355, 6361, 6362, 6364, 6367, 6377, 6379, 6380, 6382, 6399, 6755. In addition, any 4200/6200 series impulse coupled magneto which had the impulse coupling changed with an impulse coupling manufactured between February 2015 and February 2019.

**NOTE:** 15021147 = S/N manufacture date of February 2015  
19020180 = S/N manufacture date of February 2019

Impulse coupling replacement kits manufactured between Feb. 26, 2015 and Feb. 1, 2019. If it is not possible to confirm the manufactured date of the impulse coupling that is installed on a given magneto from maintenance records, the magneto must be removed from the engine in order to have the impulse coupling inspected.

**ENGINE MODELS**

**AFFECTED:** Engines utilizing Slick 4200, 4300, and 4700 series (LASAR) magnetos.  
Engines utilizing Slick 6200, 6300, and 6700 series (LASAR) magnetos.

**AIRFRAME MODELS**

**AFFECTED:** Aircraft utilizing Slick 4200, 4300, and 4700 series (LASAR) magnetos.  
Aircraft utilizing Slick 6200, 6300, and 6700 series (LASAR) magnetos.

**BACKGROUND INFORMATION:**

There have been limited reports in which impulse coupling rivets have loosened relative to the factory placement. A loose or broken rivet could potentially enter the gear train of the engine resulting in damage to the gear train or damage to engine accessories and could potentially cause catastrophic engine failure.

Proprietary Statement

The information contained in this document is proprietary property of Champion Aerospace LLC. Receipt or possession of this information does not confer, license or imply any rights to use, sell or manufacture from this information. No reproduction of publication, in whole or in part, shall be made without the express written consent of Champion Aerospace LLC. All information is covered under full protection of the United States copyright laws.

Copyright ©2019, Champion Aerospace LLC. All rights reserved.

**SUBJECT TO THE EAR, ECCN 9E991. THIS INFORMATION IS SUBJECT TO THE EXPORT CONTROL LAWS OF THE UNITED STATES, SPECIFICALLY INCLUDING THE EXPORT ADMINISTRATION REGULATIONS (EAR), 15 C.F.R. PART 730-744. TRANSFER, RETRANSFER, OR DISCLOSURE OF THIS DATA BY ANY MEANS TO A NON-U.S. PERSON (INDIVIDUAL OR COMPANY), WHETHER IN THE UNITED STATES OR ABROAD, WITHOUT ANY REQUIRED EXPORT LICENSE OR OTHER APPROVAL FROM THE U.S. GOVERNMENT IS PROHIBITED, INCLUDING WITHOUT LIMITATION ANY DIVERSION TO A MILITARY END USER OR USE IN A MILITARY APPLICATION.**

ISSUED			REVISED			Champion Aerospace LLC 1230 Old Norris Road Liberty, SC/USA 29657 ©2019 Champion Aerospace LLC	PAGE NO.	REVISION
MO	DAY	YR	MO	DAY	YR			
10	14	19				1 of 4		

# Service Bulletin

**COMPLIANCE:**

	Description	Initial Inspection	Recurring Inspection	Alternative Method of Compliance/Terminating Action
<b>Category 1</b>	All affected magnetos except those covered in Category 2	Within the next 100 hours Time in Service (TIS) but <u>not to exceed</u> 400 hours total TIS	Every 400 hours TIS until terminating action	Replace with an approved model magneto or impulse coupling replacement kit outside the affected serial number or date range. Document compliance.
<b>Category 2</b>	Affected Magnetos installed on Lycoming O/IO-540 Engines with 5th Order Counter weight	Within the next 25 hours TIS but <u>not to exceed</u> 100 hours total TIS	Every 100 hours TIS	If applicable, replace the impulse magneto with FAA-PMA approved retard-breaker Slick by Champion magneto and SureSTART ignition booster.

**PROOF OF COMPLIANCE:**

Appropriate logbook entries. Magnetos returned to Champion Aerospace for repair will be stamped with the letter "B" on the dataplate. See SB2-19 COMPLIANCE and WARRANTY INFORMATION.

**MAINTENANCE PARTS AFFECTED:**

Any 4200/4300/4700 series or 6200/6300/6700 series impulse coupled magnetos which have had the impulse coupling replaced with impulse coupling replacement kit dated Feb. 26, 2015 through Feb. 1, 2019.

**PARTS REQUIRED PER BULLETIN:**

Replacement impulse coupling as required.

**TOOLS REQUIRED:**

T-118 magneto timing pin, T-106 I/C puller, T-155 I/C rivet gauge, magneto timing light, and standard shop tools.

**WEIGHT CHANGE:**

None.

**REQUIRED SERVICE LITERATURE:**

Refer to the latest revision of Champion Slick F-1100 Master Service Manual or L-1500 LASAR Master Service Manual, as applicable, when performing the detailed instructions contained in this Service Bulletin.

**WARRANTY INFORMATION:**

Affected magnetos that fail the required inspection within the DETAILED INSTRUCTIONS (rivets are found loose) have two options for warranty resolution:

Option 1: If unit fails required inspection, order and install an Impulse Coupling Replacement Kit through an authorized Champion Aerospace Distributor. Initiate a warranty return with the Distributor for warranty credit. Distributor will provide a warranty form for completion. **Champion Aerospace reserves the right to reject warranty for any returns that are:**

- 1) Are not manufactured within the affected range.
- 2) Are subsequently found to pass the required inspection.
- 3) Are not returned with a Warranty Form.

THIS DOCUMENT SUBJECT TO THE CONTROLS AND RESTRICTIONS ON THE FIRST PAGE

ISSUED			REVISED			Champion Aerospace LLC 1230 Old Norris Road Liberty, SC/USA 29657 ©2019 Champion Aerospace LLC	PAGE NO.	REVISION
MO	DAY	YR	MO	DAY	YR		2 of 4	
10	14	19						

# Service Bulletin

Option 2: If unit fails required inspection, remove all drive gears and ship the magneto with impulse coupling to Champion Aerospace for repair. Champion will repair the Magneto by installing a new Impulse Coupling and return it to the customer at no-charge. No other repairs or inspections will be performed during this process. Customer is required to cover all inbound freight expense and ship the affected unit with an accompanying return form to:

SB2-19 Returns  
Champion Aerospace Repair Station  
1230 Old Norris Rd  
Liberty, SC 29657 USA

The magneto must have all drive gears, tach pickups, or other accessories removed and must be shipped with a completed return authorization form. **Magnetos not shipped with the completed return form or magnetos returned with drive gears or accessories installed will be rejected for repair and returned to the customer.** Repaired magnetos will be stamped with the letter "B" on the dataplate to document compliance.

**DETAILED INSTRUCTIONS:**

1. Locate magneto serial number on magneto dataplate or purchase date of replacement impulse coupling kits. If the magneto serial number or impulse coupling purchase date is determined to be within the range specified in this bulletin and the dataplate is not stamped with the letter "B" per the WARRANTY description above, remove the magneto from engine in accordance with the latest revision of the engine manufacturer's manual(s).



LETTER "B" INDICATES REPAIRED MAGNETO

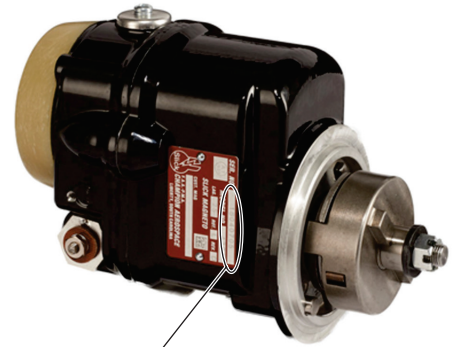

SERIAL NUMBER LOCATED ON MAGNETO DATAPLATE



MANUFACTURED DATE LOCATED ON IMPULSE COUPLING REPLACEMENT KIT

THIS DOCUMENT SUBJECT TO THE CONTROLS AND RESTRICTIONS ON THE FIRST PAGE

ISSUED			REVISED		
MO	DAY	YR	MO	DAY	YR
10	14	19			

Champion Aerospace LLC  
1230 Old Norris Road  
Liberty, SC/USA 29657  
©2019 Champion Aerospace LLC

PAGE NO.	REVISION
3 of 4	

# Service Bulletin

2. Remove, disassemble, and clean the impulse coupling per current revision of applicable magneto manual and per current revision of F-1100 Master Service Manual or L-1500 LASAR Master Service Manual.
3. Inspect the impulse coupling per the maintenance manual. If any movement is found in the rivets, the impulse coupling must be rejected. Reference WARRANTY INFORMATION for resolution options.

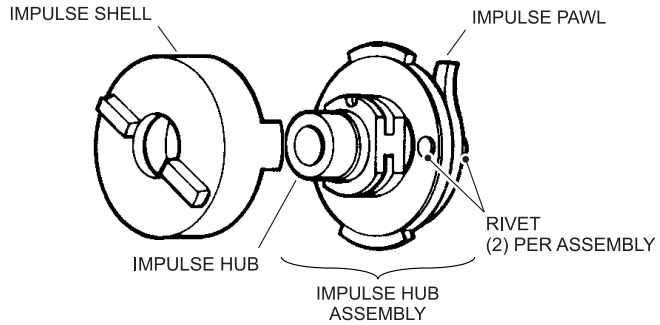

4. Repeat this recurring inspection per the requirements listed in the COMPLIANCE section.
5. In no instance shall a repair of the impulse coupling be attempted for loose rivets.
6. Liberally oil ALL new or removed impulse couplings with clean engine oil prior to installation. Make sure all castellated drive nuts are torqued to 120-320 in-lbs. Reference Champion Service Letter SL1-17 for additional information.

**NOTE:** This repair does not affect normal inspection and maintenance intervals as defined in the latest revision of the F-1100 Master Service Manual or L-1500 LASAR Master Service Manual.

**WARNING:** Slick impulse couplings are manufactured as matched assemblies. Under no circumstances should a subassembly part from one impulse coupling be used with the mating part from another impulse coupling. The maintenance practice of mixing subassembly parts, even within the same impulse coupling assembly model numbers, is not approved and can lead to impulse coupling failure and subsequent magneto and engine stoppage.

Champion Slick Piston Helpline: 904-772-1909  
 Champion Slick Technical Publication Website: [www.championaerospacepubs.com](http://www.championaerospacepubs.com)  
 Champion Slick Piston Products Technical Support E-mail: [slicksupport@champaero.com](mailto:slicksupport@champaero.com)

*THIS DOCUMENT SUBJECT TO THE CONTROLS AND RESTRICTIONS ON THE FIRST PAGE*

ISSUED			REVISED			Champion Aerospace LLC 1230 Old Norris Road Liberty, SC/USA 29657 ©2019 Champion Aerospace LLC	PAGE NO.	REVISION
MO	DAY	YR	MO	DAY	YR		4 of 4	
10	14	19						



AEROSPACE™

# SB2-19 Repair Authorization Form

This form must be completed in full and returned with the affected magneto (option 2 only). Please contact the Champion Piston Help Line at 1-904-772-1909 or [slicksupport@champaero.com](mailto:slicksupport@champaero.com) with any questions regarding eligibility or the return process.

## Questions / Eligibility:

1. Has the required inspection been performed on this magneto?  Yes  No
2. Did this unit fail the required inspection (rivets were found loose)?  Yes  No
3. Is the magneto within the affected range?  Yes  No
4. Have you removed any drive gears or other attached accessories?  Yes  No

Unit is not authorized to return for repair if you have answered “no” to any of the above questions.

## Contact Information:

Name: \_\_\_\_\_

Phone and/or Email: \_\_\_\_\_

Return Shipping Address: \_\_\_\_\_  
\_\_\_\_\_  
\_\_\_\_\_  
\_\_\_\_\_

## Magneto Information:

Model Number: \_\_\_\_\_

Serial Number: \_\_\_\_\_

Time-in-Service: \_\_\_\_\_

Engine Model: \_\_\_\_\_

**SPARK ✦ IGNITE ✦ EXCITE**

1230 Old Norris Rd • Liberty, SC • 26957

